



# Water Mist Extinguisher

## INSPECTION, MAINTENANCE AND RECHARGE SERVICE MANUAL

NO. 16303

FOR AMEREX

MODEL: B270 1¾ GALLON

MODEL: B272 2½ GALLON

“WATER MIST”



Amerex Fire International Ltd.

**WARNING: DO NOT USE THIS EXTINGUISHER ON CLASS D FIRES OR ANY FLAMMABLES THAT WILL REACT WITH WATER. PROTECT FROM FREEZING.**

All fire extinguishers should be installed, inspected and maintained in accordance with the National Fire Protection Association standard titled 'Portable Fire Extinguishers', NFA-10 and the requirements of local authorities having jurisdiction.

When maintenance is indicated it should be performed by trained persons having proper equipment. Fire extinguishers are pressure vessels and must be treated with respect and handled with care. They are mechanical devices and require periodic maintenance to be sure that they are ready to operate properly and safely. Amerex and Fire Suppression Southern strongly recommend that the maintenance of portable fire extinguisher be done by a trained professional – your authorized Amerex Distributor.

Amerex Corporation makes original factory parts available to insure proper maintenance – use of substitute parts releases Amerex and Fire Suppression Southern of its warranty obligations. Amerex parts have machined surfaces and threads that are manufactured to exacting tolerances. O-rings, hoses, nozzles, and all metal parts meet precise specifications and are subjected to multiple in-house inspections and tests for acceptability. There are substitute parts available that are incorrectly labelled as UL component parts; some are advertised as Amerex type. None of these meet UL requirements and all of them void the Amerex and Fire Suppression Southern extinguisher warranty and UL listing. **DO NOT SUBSTITUTE!**



### REFERENCES IN THIS MANUAL

AMEREX AND FIRE SUPPRESSION SOUTERN LTD DO NOT SERVICE, MAINTAIN OR RECHARGE FIRE EXTINGUISHERS. THIS MANUAL IS PUBLISHED AS A GUIDE TO ASSIST SERVICE PERSONNEL IN THE INSPECTION, MAINTENANCE AND RECHARGE OF AMEREX FIRE EXTINGUISHERS ONLY. NO INSTRUCTION MANUAL CAN ANTICIPATE ALL POSSIBLE MALFUNCTIONS THAT MAY BE ENCOUNTERED IN THE SERVICE OF FIRE EXTINGUISHERS. AMEREX AND FIRE SUPPRESSION SOUTHERN ASSUMES NO LIABILITY FOR SERVICE, MAINTENANCE OR RECHARGE OF FIRE BY PUBLISHING THIS MANUAL.

### INSPECTION

This extinguisher should be INSPECTED at regular intervals (monthly or more often if circumstances dictate) to insure that it is ready for use. INSPECTION (NFPA-10 4-2.1) is a “quick check” that an extinguisher is available and will operate. It is intended to give reasonable assurance that the extinguisher is fully charged and operable. This is done by seeing that it is in its designated place, that it has not been actuated or tampered with, and that there are no obvious physical damages or condition to prevent operation.

### MAINTENANCE

INSPECTION (NFPA-10 4-2.2). At least once a year (or more frequently if indicated by an inspection), maintenance should be performed. Maintenance is a “through check” of the extinguisher. It is intended to give maximum assurance that an extinguisher will operate effectively and safely. It includes a thorough examination and a necessary repair or replacement. It will normally reveal the need for hydrostatic testing.

### MAINTENANCE – SERVICE PROCEDURE

1. Clean extinguisher to remove dirt, grease or foreign material. Check to make sure that the instruction nameplate is securely fastened and legible. Inspect the cylinder for corrosion, abrasion, dents or weld damage. If any of these conditions are found and you doubt the integrity of the cylinder, hydrostatically test, using the proof pressure method and a suitable cage, in accordance with CHA Pamphlet C-1 and NFPA Pamphlet 10.  
**NOTE:** When cleaning avoid use of solvents around the pressure gauge. They could seriously damage the plastic gauge face.
2. Inspect the extinguisher for damaged, missing or substitute parts. Only factory replacement parts are approved for use on Amerex fire extinguishers.
3. Weigh extinguisher and compare with weight printed on the Maintenance section of the nameplate (label). Recharge extinguisher if weight is not within the indicated allowable tolerances.
4. Check the date of manufacture on the extinguisher cylinder hanger loop. Cylinder must be hydrostatically tested every 5 years to the test pressure indicated on the label 200 psi (1380 kPa). **REPLACE EXTINGUISHER AGENT WITH NEW AMEREX CHARGE AT TIME OF HYDROTEST.**



5. Visually inspect the pressure gauge:
  - a. If bent, damaged or improper gauge, depressurize and replace
  - b. If pressure is low, check for leaks
  - c. If over pressurized (overcharged), invert the extinguisher and reduce to 50 psi (345 kPa) by pressing the pressure valve. Quickly repressurize to 100 psi (690 kPa) to avoid liquid clogging the pressure valve. Check for leaks.
6. Inspect the Footstand (base). If cracked or broken replace with proper Footstand.
7. Check ring pin for freedom of movement by breaking the seal and removing the pin. Replace the ring pin if bent or if removal is difficult.
8. Inspect discharge lever for dirt or corrosion that might impair freedom of movement. Inspect carrying handle for proper installation. If lever, handle or rivets are damaged or distorted, replace with proper Amerex part(s).
9. Removal hose assembly, inspect hose assembly for damage, replace as necessary. Blow air through hose assembly to insure passage is clear of foreign material.
10. Inspect the valve assembly for corrosion or damage to hose threads connections. Replace valve assembly or component parts as necessary following the proper depressurization and recharge procedures.
11. Install hose assembly into operating valve. Torque swivel nut lightly with 15/16" wrench. Install in hose clip.
12. Install new tamper seal and record service data on the extinguisher inspection tag.
13. Rehang the extinguisher on the wall hanger bracket making sure that it fits the hanger bracket properly – replace the bracket if necessary.

### RECHARGE

RECHARGE (NFPA-10 4-2.3) is the replacement of the extinguishing agent and also includes the expellant for this type of extinguisher.

### WARNING:

- a. Before attempting to recharge be sure this extinguisher is completely depressurized
- b. Use a regulated nitrogen pressurizing source. Set the regulator no more than 25 psi (172 kPa) higher than the gauge operating pressure.
- c. Check and calibrate regulator gauge at frequent intervals. The regulator gauge should be used to determine when the intended charging pressure has been reached. Do not use the extinguisher gauge for this purpose.
- d. Never leave an extinguisher connected to a regulator of a high pressure source for an extended period of time. A defective regulator could cause the cylinder to rupture due to excessive pressure.



### RECHARGING PROCEDURE

1. Complete the "Maintenance-Service Procedure", items 1 through to 10
2. Discharge all remaining pressure and wet chemical solution, making sure that there is no remaining pressure. Do not top off or reuse water.
3. Remove the valve assembly and disassemble by removing downtube assembly (use a wrench on the brass retainer, not the plastic tube), spring and valve stem from the valve assembly. Remove the collar o-ring from the valve assembly.
4. Thoroughly rinse all parts with clean water and wipe dry with a soft cloth. Blow the valve out with air or nitrogen. Inspect the collar o-ring, valve stem and spring – replace parts if worn or damaged. Lubricate the collar o-ring and small o-ring on the valve stem with Visilox V-711 (do not lubricate the valve stem seal). Inspect the downtube. If it is cracked or deformed replace with proper downtube (see Parts List). Inspect downtube o-ring, replace if necessary.
5. Rinse the cylinder with clean water and inspect the interior following CHA Visual Inspection Standard, Pamphlet C-6.
6. Firmly replace the plastic fill tube and fill cylinder with DE-IONZINED WATER to the bottom of the fill tube. (Model B270 1.8 U.S. gal./6.81 litres Amerex Charge 670) (Model B272 2½ U.S. gals/9 ½ litres Amerex Charge 671).  
**NOTE: THE USE OF DE-IONIZED WATER IS REQUIRED.**
7. Install a "Verification of Service" collar around neck of cylinder. Install valve assembly to the cylinder and properly align.
8. Install a P/N 09492 Fill Adapter (High Performance) to the male valve outlet (where the hose assembly attaches) and pressurize with nitrogen to 100 psi (690 kPa). The pressure regulator should be set to no more than 125 psi (862 kPa). Remove Fill Adapter.  
**NOTE: DO NOT USE COMPRESSED AIR TO PRESSURIZE THIS EXTINGUISHER**
9. Check collar, gauge, cylinder welds and valve orifice for leaks using a leak detection fluid or a solution of soapy water. Remove leak detection fluid from the valve assembly by blowing out with air and wipe exterior of the extinguisher to dry.
10. Install hose & wand assembly into the operating valve.  
**NOTE: CARFEULLY POSITION THE HOSE TO A NATURAL ANGLE BEFORE TIGHTENING THE HOSE FEMALE SWIVEL NUT. TORQUE SWIVEL NUT LIGHTLY USING 15/16" WRENCH. INSTALL IN HOSE CLIPS.**
11. Install ring pin with ring facing front of the extinguisher. Install new tamper seal. Record recharge date and attach new recharge tag.
12. Weigh assembled extinguisher and confirm that the total weight is within the allowable tolerances indicated in the Maintenance section on the extinguisher nameplate (label).



### TROUBLESHOOTING GUIDE

**WARNING:**

Determine the source of leak before the extinguisher is depressurized. THE EXTINGUISHER MUST BE COMPLETELY DEPRESSURIZED BEFORE ANY ATTEMPT IS MADE TO DEVALVE IT AND CORRECT ANY LEAKGE PROBLEM. To depressurize – hold the extinguisher in an inverted position and slowly squeeze the discharge handle. Some liquid remaining in the downtube will be discharged to care should be taken in the area used for depressurization. Thoroughly clean all valve parts after depressurization and valve removal.

	<b>PROBLEM</b>	<b>CORRECTIVE ACTION</b>
1.	Leak at collar o-ring	Remove valve assembly, clean collar (knurled) nut thoroughly and install new o-ring. Lubricate o-ring with Visilox V-711.
2.	Leak through valve	Install new valve stem assembly. Check valve seat for scratches or foreign matter.
3.	Leak around gauge threads	Remove gauge* and reinstall using Teflon tape on the gauge threads.
4.	Defective gauge	Remove defective gauge* and install a new P/N 06479 gauge using Teflon tape on the gauge threads
5.	Leak in cylinder	Contact Fire Suppression Southern Ltd if under warranty, otherwise mark 'REJECTED' and return to owner
6.	Broken Footstand	Install new P/N 03109 Footstand using Dow corning RTV-732 Silicone Rubber adhesive, Amerex P/N 04488
Pressure gauge threads are coated with a special epoxy at the factory. For easy removal soak the valve assembly (minus the downtube assembly) in hot water (180°F/82°C) for two to four minutes. Remove gauge with a 7/16" open end wrench.		

# Fire Suppression Southern Ltd

Amerex Fire Suppression Systems



## PARTS LIST

For

1 ¾ GAL. "WATER MIST" – MODEL B270

2 ½ GAL. "WATER MIST" – MODEL B272

Stored Pressure Stainless Steel Extinguishers (Brass Valve)

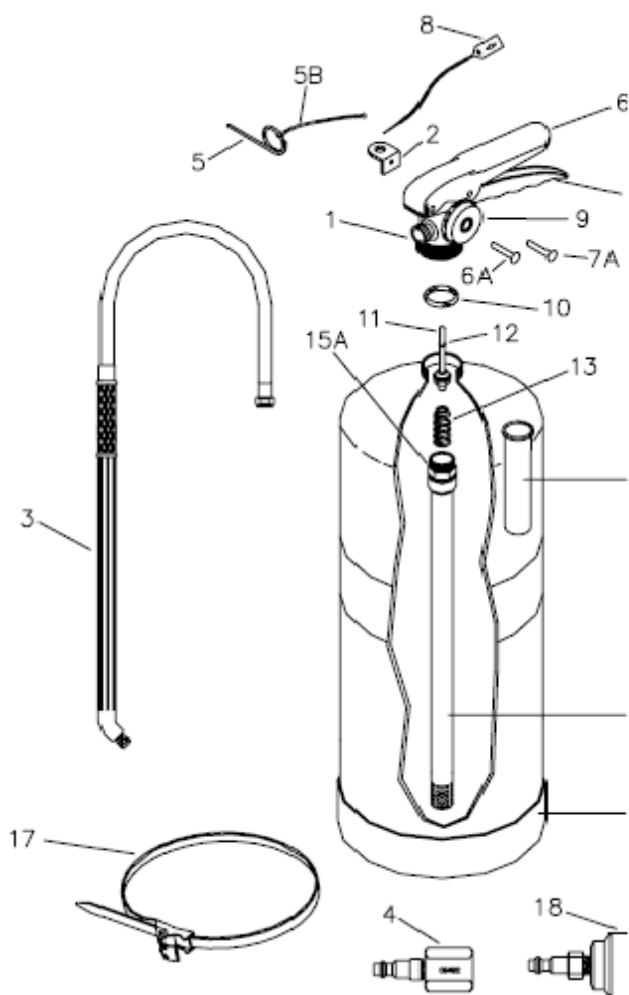

ITEM NO.	PART NO.	DESCRIPTION	STD PKG
1	14249	Valve Assembly	1
2	14380	Hanger Loop w/Screw (optional)	6
3	14318	Hose & Wand Assembly - B270	1
	14184	Hose & Wand Assembly - B272	1
4	09492	Fill Adapter	1
5	00160	Ring Pin Stainless Steel	24
5A	06901	Ring Pin Non-Mag SS (Optional)	24
5B	00532	Chain(Nylon) for Ring Pin	24
6	07762	Lever & Rivet	1
6A	01563	Rivet only for Lever	24
7	09020	Handle & Rivets	1
7A	01564	Rivet only for Handle (2 required)	24
8	01387	Lockwire Seal (Yellow)	500
9	06479	100 psi Pressure Gauge (SS Tube)	6
10	05240	Collar O-ring	24
11	06093	Valve Stem Assy	6
12	05243	Valve Stem O-ring	24
13	00383	Spring	6
14	14316	Fill Tube - 270 (Red)	1
	02595	Fill Tube - 272 (White)	
15	16060	Downtube/Retainer Assembly - B270	1
	16059	Downtube/Retainer Assembly - B272	
15A	05690	O-ring - Downtube/Retainer	12
16	14187	Footstand (blue)	1
17	14838	Strap & Clip Assembly (Blue Plastic) 3/8" (2 required)	6
18	03181	Hydrotest Adapter	1
♦	16302	Model 670 2 ea 13/4g. De-Ionized Water	2
	16363	Model 671 2 ea 2-1/2g. De-Ionized Water	
♦	01007	Wall Bracket - Red	1
	14315	Wall Bracket (SS Non-Mag) (Optional)	
♦	04488	Adhesive (3 oz. tube for Footstand)	1
♦	06247	Visilox Lubricant (5 oz. Tube)	1
<b>NOTE:</b>		All Valve Assemblies include new Valve Body, Pressure Gauge, Wing Nut, Lever and Handle	
		♦ PARTS NOT PICTURED	

# Water Mist Extinguisher